

DUAL CHANNEL RAPID CHARGER

NT09E-100

OPERATION MANUAL



**ONE
TECH**

ONETECH

Tools



ATTENTION! PLEASE READ THIS MANUAL BEFORE USING THE TOOL.

IMPROPER USE OF TOOL MAY CAUSE INJURY AND/OR PROPERTY DAMAGE!

ONLY QUALIFIED AND SPECIALLY TRAINED PERSONNEL FAMILIED WITH THESE INSTRUCTIONS IS ALLOWED TO USE AND MAINTENANCE OF THE TOOL.

Safety recommendations contained in present manual are in addition to general safety regulation in force in the region of tool usage, and do not replace it.



➤ Risk of hit by moving parts.

➤ Increased noise and vibration level may occur.

➤ Risk of increased dust content in the air of working zone.



➤ Risk of fire and short circuit if the wire contacts source of fire and heat.

➤ Electric shock hazard.



1. IMPORTANT SAFETY INSTRUCTIONS

- **SAVE THESE INSTRUCTIONS - THIS MANUAL CONTAINS IMPORTANT SAFETY AND OPERATING INSTRUCTIONS FOR THE Li-ion CHARGER.**
- **BEFORE USING THE BATTERY PACK AND CHARGER, READ THIS OPERATOR'S MANUAL, YOUR TOOL OPERATOR'S MANUAL, AND ALL LABELS ON THE BATTERY PACK, CHARGER AND TOOL.**
- **TO REDUCE THE RISK OF INJURY, CHARGE RECHARGEABLE Li-ion BATTERIES ONLY IN CHARGERS.** Other types of batteries may burst causing personal injury and damage. Do not wire a battery pack to a power supply plug or car cigarette lighter. Batteries will be permanently disabled or damaged.
- **USE ONETECH Li-ion PACKS ONLY ON COMPATIBLE ONETECH Li-ion TOOLS.** Use with other tools may result in a risk of fire, electric shock or personal injury.
- **AVOID DANGEROUS ENVIRONMENTS.** Do not charge battery pack in rain, snow, damp or wet locations. Do not use battery pack or charger in the presence of explosive atmospheres (gaseous fumes, dust or flammable materials) because sparks may be generated when inserting or removing battery pack, possibly causing fire.
- **CHARGE IN A WELL-VENTILATED AREA.** Do not block charger vents. Keep them clear to allow proper ventilation. Do not allow smoking or open flames near a charging battery pack. Vented gases may explode.
- **MAINTAIN CHARGER CORD.** When unplugging charger, pull plug rather than cord to reduce the risk of damage to the electrical plug and cord. Never carry charger by its cord. Keep cord from heat, oil and sharp edges. Make sure the cord will not be stepped on, tripped over or subjected to damage or stress. Do not use charger with damaged cord or plug. Have a damaged charger replaced immediately.
- **DO NOT USE AN EXTENSION CORD UNLESS IT IS NECESSARY.** Using the wrong, damaged or improperly wired extension cord could result in the risk of fire and electrical shock. If an extension cord must be used, plug the charger into a properly wired 16 gauge or larger extension cord with pins that are the same number, size and shape as the pins on the charger. Make sure that the extension cord is in good electrical condition.
- **CHARGER IS RATED FOR 100-240 VOLT AC.** Charger must be plugged into an appropriate receptacle.
- **USE ONLY RECOMMENDED ATTACHMENTS.** Use of an attachment not recommended or sold by the battery charger or battery pack manufacturer may result in a risk of fire, electric shock or personal injury.
- **UNPLUG CHARGER WHEN NOT IN USE.** Remove battery packs from unplugged chargers.

- **TO REDUCE THE RISK OF ELECTRIC SHOCK**, always unplug charger before cleaning or maintenance. Do not allow water to flow into AC/DC plug. Use a Ground Fault Circuit Interrupter (GFCI) to reduce shock hazards.
- **DO NOT BURN OR INCINERATE BATTERY PACKS**. Battery packs may explode, causing personal injury or damage. Toxic fumes and materials are created when battery packs are burned.
- **DO NOT CRUSH, DROP, OR DAMAGE** battery pack. Do not use a battery pack or charger that has received a sharp blow, been dropped, run over, or damaged in any way (e.g., pierced with a nail, hit with a hammer, stepped on).
- **DO NOT DISASSEMBLE**. Incorrect reassembly may result in the risk of electric shock, fire or exposure to battery chemicals. If it is damaged, take it to a Seller's service center or ONETECH representatives.
- **BATTERY CHEMICALS CAUSE SERIOUS BURNS**. Never allow contact with skin, eyes, or mouth. If a damaged battery pack leaks battery chemicals, use rubber or neoprene gloves to dispose of it. If skin is exposed to battery fluids, wash with soap and water and rinse with vinegar. If eyes are exposed to battery chemicals, immediately flush with water for 20 minutes and seek medical attention. Remove and dispose of contaminated clothing.
- **DO NOT SHORT CIRCUIT**. A short-circuited battery pack may cause fire, personal injury, and product damage. A battery pack will short circuit if a metal object makes a connection between the positive and negative contacts on the battery pack. Do not place a battery pack near anything that may cause a short circuit, such as coins, keys or nails in your pocket.
- **DO NOT ALLOW FLUIDS TO FLOW INTO BATTERY PACK**. Corrosive or conductive fluids, such as seawater, certain industrial chemicals, and bleach or bleach containing products, etc., can cause a short circuit.
- **STORE YOUR BATTERY PACK AND CHARGER IN A COOL, DRY PLACE**. Do not store battery pack where temperatures may exceed 40°C such as in direct sunlight, a vehicle or metal building during the summer.
- **THIS CHARGER AND BATTERY PACK ARE NOT INTENDED FOR USE BY CHILDREN AND PERSONS WITH PHYSICAL, SENSORY OR MENTAL LIMITATIONS OR A LACK OF EXPERIENCE OR KNOWLEDGE.**

2. SPECIFICATIONS

Model	Input	Rated input power, W	Output 1	Output 2	Recommended ambient
NT09E-100	100-240 V~ 50-60 Hz	160	18 VDC, 6.5 A	18 VDC, 6.5 A	+4 °C to +40 °C

3. SYMBOLOGY



Before switching on the power tool, read the operating manual!



Device is suitable for use indoors only. Store electric power tool in dry rooms.



There is a risk of electric shock in case of incorrect use.



Only charge batteries at temperatures between +4 °C to +40 °C. Protect the battery from heat, e.g. from continuous exposure of sunlight and fire.



Do not throw device in the fire. There is a risk of explosion.



Do not expose the device to rain; keep the device away from water.



Recycling raw materials instead of waste disposal.

Do not throw the electric power tools into the household waste! Power tools must be collected separately and recycled in an environmentally friendly manner.

4. INTENDED USE

The battery charger is designed for charging ONETECH batteries NT09E-101, NT09E-102. Estimated Charging Time 30 - 60 min.

- Compliant types are not limited to the above list, refer to our website for update.
- The battery voltage must match the battery charging voltage of the charger. Otherwise, there is danger of fire and explosion.
- Depending on charge state, heavily cycled batteries may take longer to charge completely.

5. FUNCTIONAL DESCRIPTION

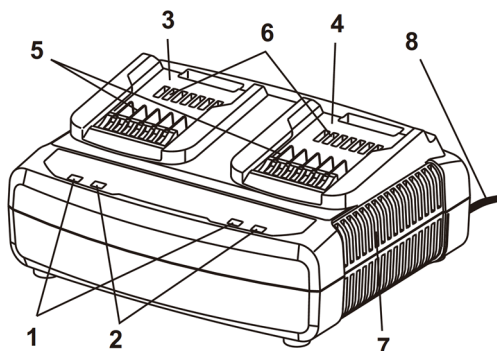

1. Red Lights
2. Green lights
3. Output Bay-1
4. Output Bay-2
5. Electrical Contacts
6. Vents for Battery Cooling
7. Charger Vents
8. Cord

- The «red light» may come on, either continuous (battery pack is too hot or cold), or flashing (battery pack is faulty).
- The «green light» will come on, flashing quickly (pack is charging).
- The «green light» come to flashing slowly (charging is approaching full), this pack is 80% full, it can use now, but it is suggested to continue the charging until it is fully charged.
- When charging starts at any of the bays, the corresponding cooling fan starts to run.
- After charging is complete, the «green light» will come continuous on.
- Use the indicator button on the battery pack to show the how fully charged the pack is.
- The charger will keep the battery pack fully charged if it is left on the charger.
- The charger will charge the 2 battery packs in turns, the first pack been inserted in will be charged firstly, the «green light» near the 2nd pack flashing very slowly (battery pack is waiting for another pack to finish charging).
- Mounting to the Wall: Use the wall mount guides to mark the hanging points.

9. STORAGE AND MAINTENANCE

- Store your charger in a cool, dry place.
- Unplug battery chargers and remove batteries when not in use.

WARNING! To reduce the risk of injury, always unplug the charger and remove the battery from the charger before performing any maintenance.

Never disassemble the battery or charger. Contact Seller's service facility or ONETECH representatives for ALL repairs.

- Clean out dust and debris from charger vents and electrical contacts by blowing with compressed air.
- Remove dirt and dust from the housing with a paint brush or dry cloth, keeping away from all electrical contacts.
- Never use flammable or combustible solvents around batteries, charger, or tools.
- Never immerse your battery or charger in liquid or allow Indicator a liquid to flow inside them.

10. DECLARATION OF CONFORMITY

We declare under our sole responsibility that the product described under "Technical Data" conforms to the following standards or normative documents:

EN 60335-1
EN 60335-2-29
EN 55014-1
EN 55014-2
EN 61000-3-2
EN 61000-3-3
EN 62233: 2008
2014/35/EU
2014/30/EU

6. EXEMPTION FROM LIABILITY

The manufacturer and his representative are not liable for any damage and lost profit due to interruption in business caused by the product or by an unusable product.

The manufacturer and his representative are not liable for any damage which was caused by improper use of the battery pack or by use of the battery pack with products from other manufacturers.



info@onetech-tools.com



www.onetech-tools.com

