

MANUAL GRAVITY MINI SPRAY GUN

NT-400R

OPERATION MANUAL



**ONE
TECH
CH**

ONETECH

Tools

ATTENTION! PLEASE READ THIS MANUAL BEFORE USING THE SPRAY GUN (TOOL).

IMPROPER USE OF TOOL MAY CAUSE INJURY AND/OR PROPERTY DAMAGE!

ONLY QUALIFIED AND SPECIALLY TRAINED PERSONNEL FAMILIED WITH THESE INSTRUCTIONS IS ALLOWED TO USE AND MAINTENANCE OF THE TOOL.

This manual contains description, safety rules and all the information necessary for the correct use of the spray gun.

The safety advice given in this manual is in addition to and does not replace the general safety regulations applicable in the region where the tool is used.

➤ Sprayed materials (paints, solvents, etc.) can be harmful to health. Always read all labels, safety data sheets and follow any recommendations for the material before spraying. If in doubt, contact your material supplier. The use of respiratory protective equipment is recommended at all times.



➤ Always wear eye protection when spraying or cleaning the spray gun.

➤ Gloves must be worn when spraying or cleaning the equipment.

➤ Static electricity can be generated by fluid and/or air passing through hoses, by the spraying process and by cleaning non-conductive parts with cloths. To prevent ignition sources from static discharges, earth continuity must be maintained to the spray gun and other metallic equipment used. It is essential to use conductive air and/or fluid hoses.

➤ Sparks, open flames or hot surfaces can create a fire or explosion.



➤ **To reduce the risk of injury, user must read and understand operator's manual.**



GENERAL RULES OF OPERATION

- When working with the tool always use personal protective equipment appropriate for the type of work performed (goggles, impact resistant glasses, hand protection, body, etc.);
- The employee's appearance must comply with safety requirements;
- Use spray gun only for its intended purpose;
- Observe grounding rules in the workplace;
- To ensure maximum performance and durability of the tool, the working pressure of the compressed air must match the spray technology;
- High noise levels can cause hearing loss. Timely maintenance will help avoid an increase in noise levels;
- The flow of compressed air can cause serious injury. Never direct the air flow towards yourself or others. Do not use compressed air to clean clothes;
- Before starting work, check the compressed air supply hose for damage, wear or other defects. Replace immediately if found;
- Check screw connections before starting work. Tighten if necessary;
- Do not carry the tool by the compressed air supply hose;
- Always disconnect the tool from the compressed air line before performing maintenance;
- Use materials and solvents that are compatible with the spray gun parts. Do not use solvents or products containing acids;
- Avoid prolonged exposure to solvents on non-metallic parts of the spray gun.
- Flush spray gun before starting use, before changing materials and at the end of work. Do not use methylene chloride 1,1,1-trichloroethane for flushing. These solvents can chemically react with aluminum gun parts.

PURPOSE

Pneumatic gravity spray gun is designed to apply liquid and low-viscosity materials (varnishes, enamels, primers, etc.) to the surface to be treated manually, by pneumatic spraying.

These spray guns are suitable for use with both waterbased and solvent based coating materials. These guns are not designed for use with highly corrosive and/or abrasive materials and if used with such materials it must be expected that the need for cleaning and/or replacement of parts will be increased. If there is any doubt regarding the suitability of a specific material, contact your ONETECH Distributor or ONETECH direct.

OPERATING PRINCIPLE

- ✓ The air flow required for spraying is supplied to the spray gun through a suitable air inlet connection.
- ✓ When you press the trigger, the air flow, passing through the corresponding channels in the spray gun body, exits through the holes in the air cap.
- ✓ When exiting through the holes in the air cap, the air stream mixes with the sprayed material, and the additional directional flow breaks the material into small droplets and forms a paint spray.

MAINTENANCE

- ✓ To clean air cap and fluid nozzle, brush exterior with a stiff bristle brush. If necessary to clean cap holes, use a broom straw or toothpick if possible. If a wire or hard instrument is used, extreme care must be used to prevent scratching or burring of the holes which will cause a distorted spray pattern.
- ✓ To clean fluid passages, remove excess material from cup, then flush with gun wash solution. Wipe the gun exterior with a dampened cloth. Never completely immerse in any solvent or cleaning solutions as this is detrimental to the lubricants and life of the spray gun.

STORAGE

- Avoid storing the instrument in conditions of high humidity.
- Lubricate the tool before long-term storage (see MAINTENANCE).

DISPOSAL

- When disposing of the tool or individual components, observe the local regulations in force in the region where the equipment is used.

THE AIR SUPPLY SYSTEM

- Always use clean, dry air.
- Recommended diameter of the compressed air hose ID \approx 9 mm (3/8").
- Maintain the necessary supply of compressed air in the air line for trouble-free and optimal tool performance.

EXAMPLE OF AIR SUPPLY SYSTEM

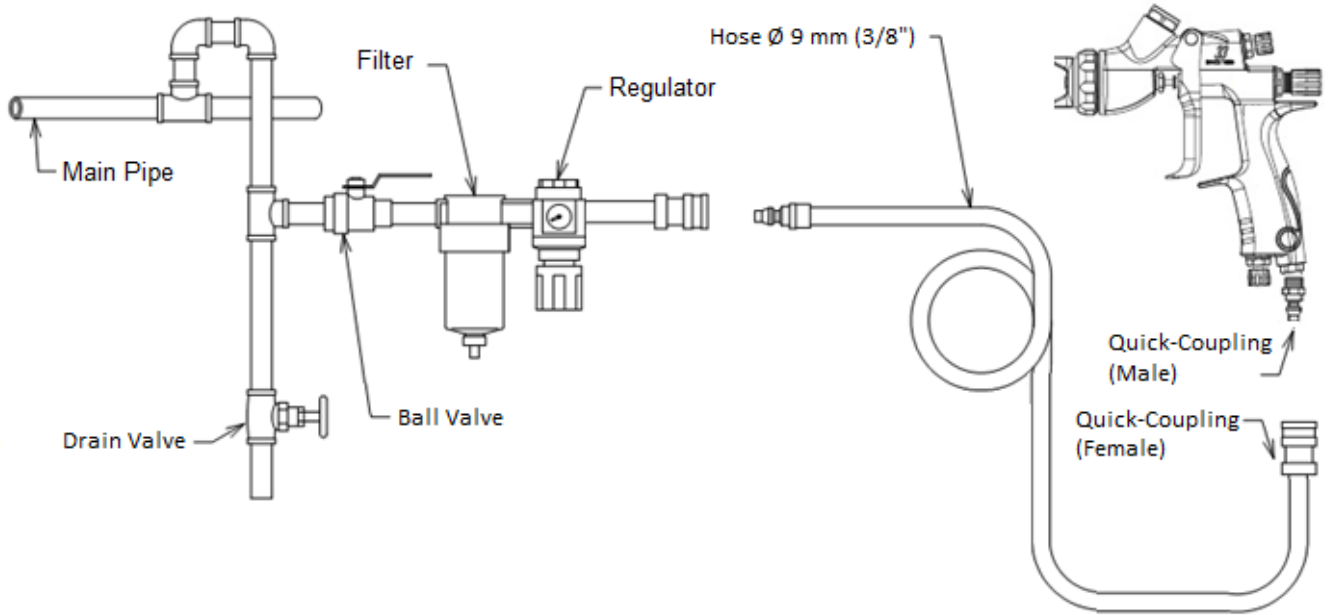

TECHNICAL SPECIFICATION

Model	Nozzle size, mm	Air Pressure, bar	Air Consumption, lpm	Fluid Output, ml/min	Spray width, ± 20 mm*	Weight, g
NT10-400R-04	0.4	2.0 – 2.5	30	15	25	270
NT10-400R-06	0.6			35	35	
NT10-400R-08	0.8		50	60	38	
NT10-400R-10	1.0			65	40	

Material Inlet Thread	Air Inlet Thread
1/4" (M)	1/4" (M)

* – spraying distance – 150 mm, fluid viscosity – 11-15 seconds.

Note: weight indicated without fluid cap

TROUBLESHOOTING GUIDE



FLUTTERING

Possible Cause	Solution
Insufficient material in cap	Refill material
Dry or worn fluid needle packing set or loose fluid needle packing screw	Lubricate or replace fluid needle packing set or tighten fluid needle packing screw
Loose or damaged fluid nozzle	Tighten or replace fluid nozzle



CRESCENT

Possible Cause	Solution
Material store-up on air cap	Clean air cap with proper objects



HEAVY TOP OR BOTTOM

Possible Cause	Solution
Material store-up on air cap	Clean or replace air cap
Dirty or damaged fluid nozzle	Clean or replace fluid nozzle



SPLIT

Possible Cause	Solution
Material too thin or too much	Increase material viscosity
Atomizing air pressure too high	Reduce air pressure



HEAVY CENTER

Possible Cause	Solution
Material too thick or too much	Reduce material viscosity
Atomizing air pressure too low	Increase air pressure

MATERIAL DRIPS FROM FLUID NOZZLE

Possible Cause	Solution
Obstructions between fluid nozzle and fluid needle	Clean fluid nozzle and fluid needle in thinner
Worn fluid nozzle or needle	Replace part

MATERIAL LEAKS FROM NEEDLE PACKING SCREW

Possible Cause	Solution
Loose fluid needle packing screw	Tighten fluid needle packing screw, check fluid needle for free movement

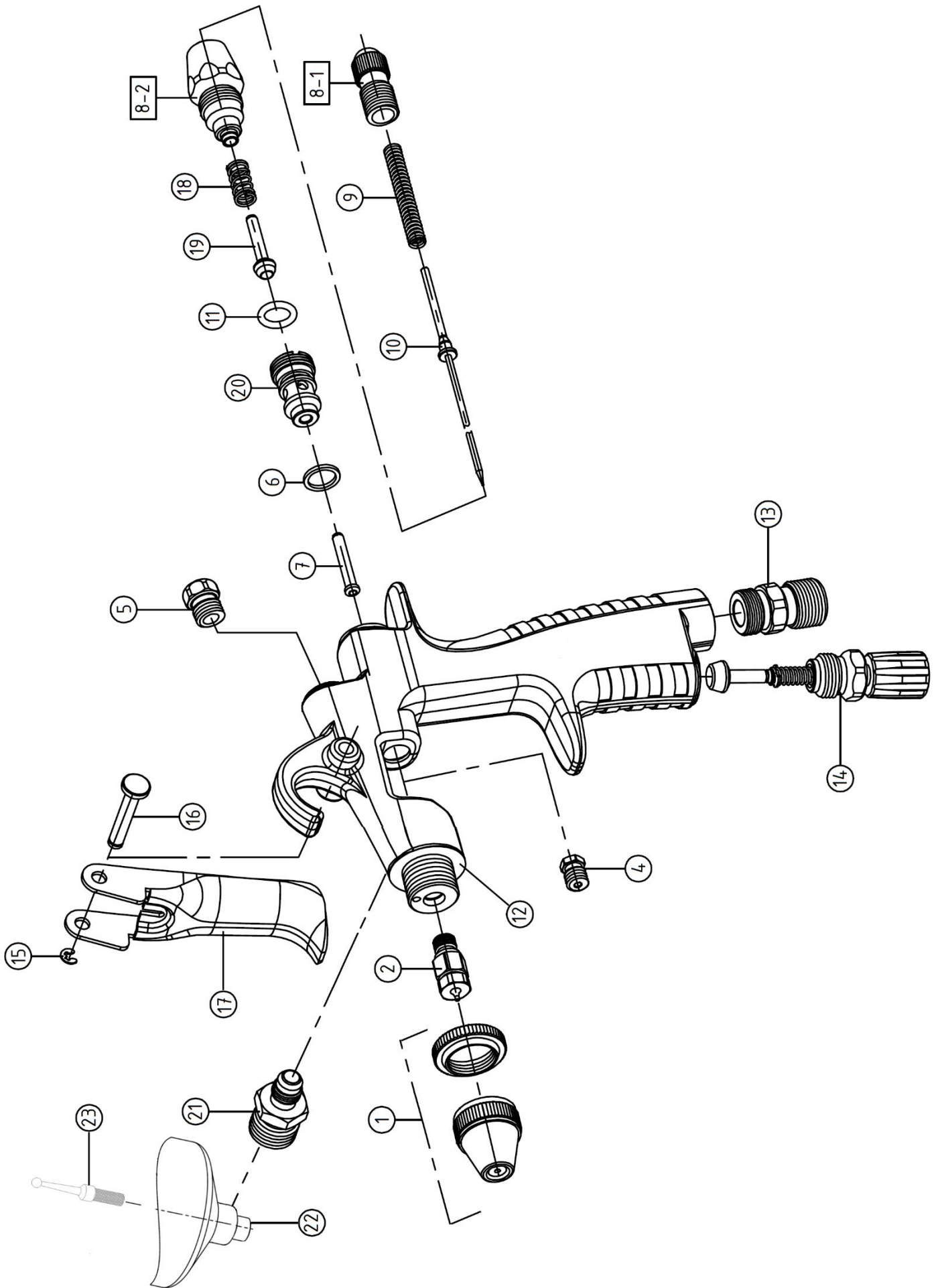

No.	Description	Part No.
1	Air cap 04	NT10S-283
	Air cap 06	NT10S-272
	Air cap 08	NT10S-273
	Air cap 10	NT10S-274
2	Fluid nozzle (0.4)	NT10S-193
	Fluid nozzle (0.6)	NT10S-194
	Fluid nozzle (0.8)	NT10S-195
	Fluid nozzle (1.0)	NT10S-196
4	Fluid needle packing screw set	NT10S-197
5	Pattern adjusting set	NT10S-198
6	Air valve seat packing	NT10S-148
7	Fluid needle guide	NT10S-149
8-1	Fluid adjusting knob	NT10S-150
8-2	Fluid adjusting knob guide set	NT10S-151
9	Fluid needle spring	NT10S-152
10	Fluid needle set (0.4)	NT10S-199
	Fluid needle set (0.6)	NT10S-200
	Fluid needle set (0.8)	NT10S-201
	Fluid needle set (1.0)	NT10S-202

No.	Description	Part No.
11	O-ring	NT10S-158
12	Gun body	NT10S-203
13	Air connector	NT10S-160
14	Air adjusting set	NT10S-161
15	Locking ring	NT10S-162
16	Trigger stud	NT10S-163
17	Trigger	NT10S-164
18	Air valve spring	NT10S-165
19	Air valve	NT10S-166
20	Air valve seat set	NT10S-167
21	Fluid connector	NT10S-184
22	Fluid cap 150 ml., 1/4" (M)	NT05-RC-51SR
23	Filter	NT10S-185
–	Fluid nozzle (0.4) + Fluid needle	NT10S-204
–	Fluid nozzle (0.6) + Fluid needle	NT10S-205
–	Fluid nozzle (0.8) + Fluid needle	NT10S-206
–	Fluid nozzle (1.0) + Fluid needle	NT10S-207
–	Air valve set (pos. 6, 7, 11, 19, 20)	NT10S-175



info@onetech-tools.com



www.onetech-auto.com

www.onetech-tools.com

